

PQ - PQA



ELECTROPOMPES PERIPHERIQUES A ASPIRATION LATERALE

PRINCIPE : Mono turbine à aubes périphériques radiales.

Moteurs haut rendement classe IE3 (triphasés ≥ 0.75 kW).

UTILISATION :

- Faibles débits, hautes pressions, pour liquides propres.
- Recyclages industriels, chaudières, tous usages domestiques.
- Température du liquide : de - 10°C (avec antigel) à + 90°C.
- Température ambiante : 40°C maxi (45°C maxi pour PQ60).

CONSTRUCTION :

- Corps en fonte traitée cataphorèse PN 6 bars (\leq PQ65), PN 10 bars (\leq PQ300) (Corps en technopolymère RYTON pour PQA ou laiton pour PQ-BS, PN 10 bars).
- Roue laiton, lanterne aluminium avec insert anti-blocage brevetée N°IT1243605.
- Moteur 2900 tr/min, IPX4, classe F, S1 (service continu).
- Tensions : MONO 220÷230V ou TRI 230/400V (50 Hz).
- Arbre INOX EN 10088-3 - 1.4104.
- Garniture mécanique de série en carbone/céramique/nitrile (carbone/carbure/nitrile sur PQ70 à PQ90 et PQ-BS).
- Protection thermique incorporée en monphasé.



PQ



PQ-BS



PQA



Modèle déposé N°0001520591 PQm 60.



Désignation	Code	Prix HT	kW	Q = débit en m ³ /h													
				0.24	0.36	0.6	0.9	1.2	1.5	1.8	2.1	2.4	3.0	4.2	5.4		
* PQm 60®	A1B0040	150	0.37	39	36	33.5	29	24	19.5	15	10	5					
PQ 60®	A1B0050	155										CORPS RYTON					
* PQAm 60	A1B0045	229	0.37	36	34	29	23.5	18	12.5	7					CORPS RYTON		
PQA 60	A1B0055	248															
* PQm 65	A1B0060	212	0.50	51	49	45.5	40.5	36	31	27	22	17	8				
PQ 65	A1B0070	218															
* PQm 70	A1B0080	275	0.60	63	61	57	52	47	42	37	32	27	18				
PQ 70	A1B0090	275															
* PQAm 70	A1B0085	318	0.55	59	57	52	45.5	39.5	33	27	19	16					
PQA 70	A1B0095	334										CORPS RYTON					
* PQm 80	A1B0100	298	0.75	67	65	61	56	51	46	41	36.5	31	22				
PQ 80	A1B0110	298															
* PQm 81	A1B0010	275	0.50	71	63	45	27	8									
PQ 81	A1B0020	275															
* PQm 81-BS	A1B0024	375	0.50	71	63	45	27	8									
PQ 81-BS	A1B0025	375										CORPS LAITON					
* PQm 90	A1B0120	349	0.75	83	81	71	60	49	38	27	17	5					
PQ 90	A1B0130	349															
PQ 100	A1B0140	517	1.10	81	79	75	70	65	60	55	50	45	35	15			
PQ 200	A1B0150	548	1.50	87	85	81	76	71	65.5	60	55	50	40	20			
PQ 300	A1B0180	612	2.20	96	94	90	85	80	75	70	65	60	50	30	10		

m = monphasé

H M T = Hauteur manométrique totale en m (10 m CE = 1 bar)

* éco-participation 0.42€ HT en sus

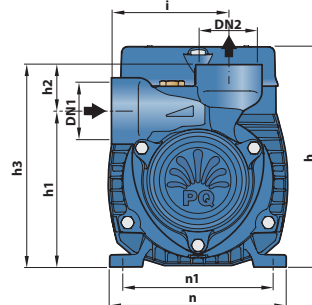
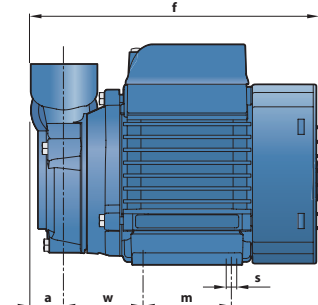

TYPE		ISO 228/1		DIMENSIONS en mm												
Monphasé	Triphasé	DN1	DN2	a	f	h	h1	h2	h3	i	m	n	n1	w	s	poids kg
PQm 60	PQ 60	1"	1"	22	190	145	101	30	131	76	55	118	93/100	53	7	6
PQAm 60	PQA 60	1/2"	1/2"	25	192	145	96	33	129	72.5	55	118	93/100	53	7	5
PQm 65	PQ 65	1"	1"	22	220	152	113	30	143	78	80	120	100	53	7	7
PQm 70/80	PQ 70/80	1"	1"	22	255	180	121	30	151	83	90	138	112	62	7	10
PQAm 70	PQA 70	1/2"	1/2"	28	258	179	116.5	32.5	149	72.5	90	138	112	62	7	10
PQm 81 + BS	PQ81 + BS	1/2"	1/2"	18	218	152	119	22	141	71	80	120	100	56	7	7
PQm 90	PQ 90	3/4"	3/4"	22	255	180	126	27	153	84	90	138	112	62	7	10
-	PQ 100/200/300	1"	1"	25	318	212	140	30	170	89	100	164	125	85	9	15